

DH-PFB604WA

Corrosion-proof Wall Mount Bracket of 14" Housing



Features

- Material: Aluminum
- Corrosion-proof wall mount bracket
- Hidden line design
- Aesthetic design

Technical Specifications

Model	DH-PFB604WA
General	
Material	Aluminum
Dimension	264.0mm x 100.0mm x 146.0mm (10.39" x 3.94" x 5.75")
Inch Thread	M20(G1/2")
Load Bearing	4.0kg(8.82lb)
Weight	0.6kg(1.32lb)
Color	White
Operating Temperature	-40°C ~ +60°C (-40°F ~ +140°F)
Humidity	0~90% RH
Applicable Model	PFH610A series, please see "Accessory Selection"

Order Information

Type	Part Number	Description
Camera mount	DH-PFB604WA	Housing corrosion-proof wall mount bracket
	PFB604WA	Housing corrosion-proof wall mount bracket
	DH-PFA140A	Corrosion-proof power box
	PFA140A	Corrosion-proof power box

Dimensions (mm/inch)

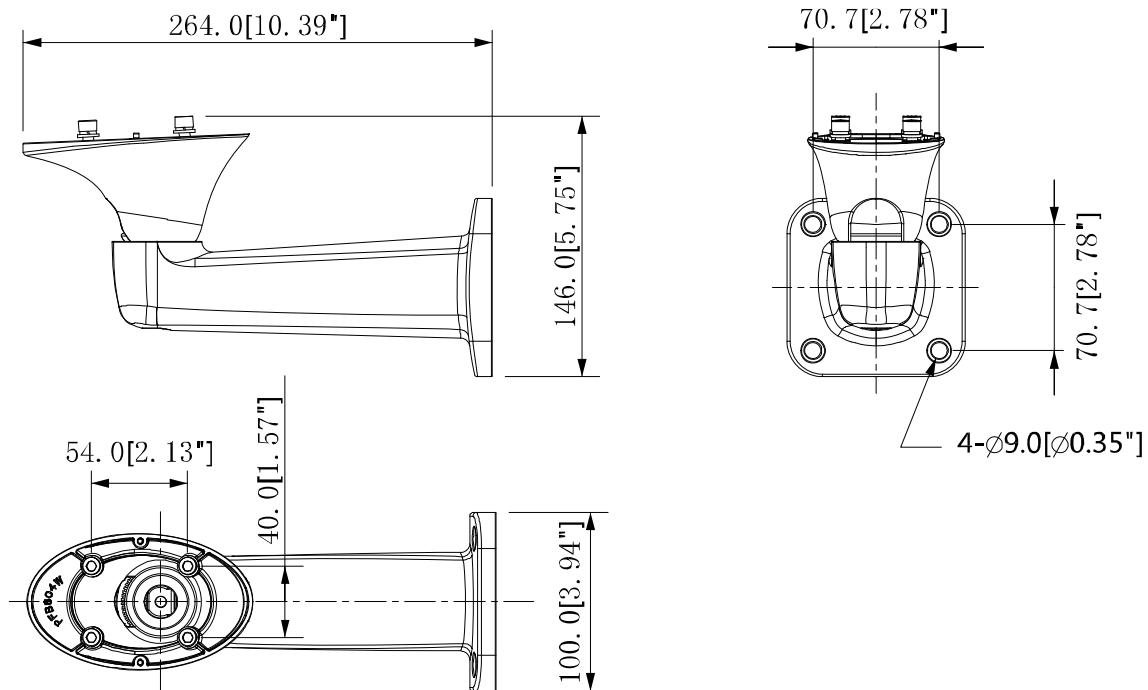

Application

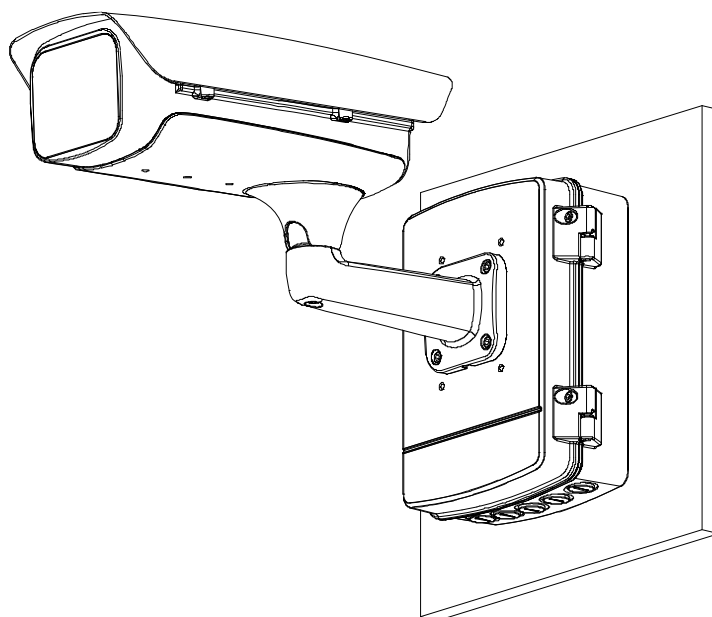

Package Information

- Housing corrosion-proof bracket *1
- ST6x45 screw *4
- Plastic anchor *4
- Wrench *1