

# DH-PFB205W-E

## Wall Mount Bracket



- Aluminum alloy material, cost-effective
- Dedicated for particular cameras, beautiful and elegant designed



### Series overview

Ideal for mounting cameras, it works in temperatures ranging from  $-40^{\circ}\text{C}$  to  $+60^{\circ}\text{C}$  ( $-40^{\circ}\text{F}$  to  $+140^{\circ}\text{F}$ ) and in environments with relative humidity of less than 90%.

### Technical Specification

#### Structure

Material	Aluminum alloy
Dimensions	161.6 mm × 125.6 mm × 76.0 mm (6.36" × 4.94" × 2.99") (L × W × H)
Color	White
Net Weight	0.49 kg (1.08 lb)
Gross Weight	0.56 kg (1.23 lb)
Load Bearing	2.0 kg (4.41 lb)
Installation	Wall mount
Applicable Camera	Please see "Accessory Selection"
Product Dimensions	128.0 mm × 81.0 mm × 170.0 mm (5.04" × 3.19" × 6.69") (L×W×H)
Packaging Dimensions	427.0 mm × 272.0 mm × 363.0 mm (16.81" × 10.71" × 14.29") (L × W × H)
Packaging Method	20 pcs in each master carton

#### Environment

Operating Temperature	$-40^{\circ}\text{C}$ to $+60^{\circ}\text{C}$ ( $-40^{\circ}\text{F}$ to $+140^{\circ}\text{F}$ )
Operating Humidity	< 90% (RH)
Storage Temperature	$-40^{\circ}\text{C}$ to $+60^{\circ}\text{C}$ ( $-40^{\circ}\text{F}$ to $+140^{\circ}\text{F}$ )
Storage Humidity	10%–90% (RH)

### Ordering Information

Type	Model	Description
Camera Mount	DH-PFB205W-E	Wall Mount Bracket

### Installation

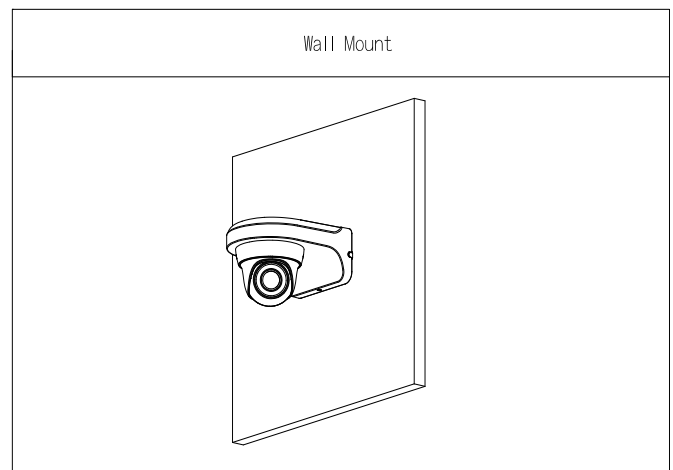

Dimensions (mm[inch])

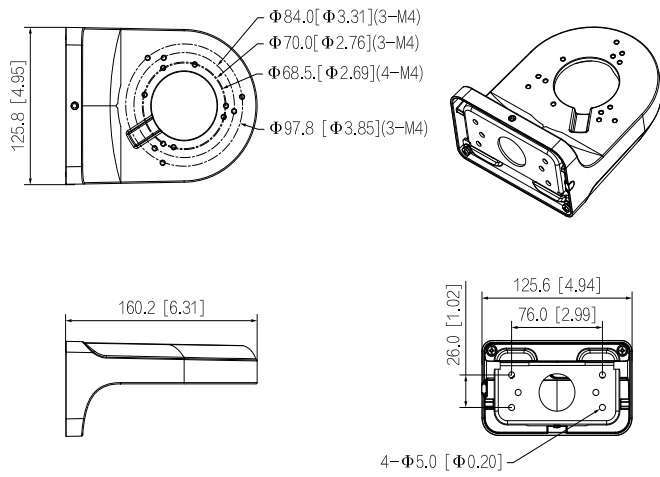

Package Information

- Wall Mount Bracket \*1
- M4x10 screws \*4
- ST4x25 screws \*4
- Plastic expansion bolt \*4
- S3.0 wrench \*1