

DH-PFA13G

Junction Box



- Aluminum alloy material, cost-effective
- Dedicated for particular cameras, beautiful and elegant designed
- Cabling inside the junction box
- Cable threading through bottom or side



Technical Specification	
Material	Aluminum alloy
Dimensions	Φ111.6 mm × 36.0 mm (Φ4.39" × 1.42")
Pipe Thread	G1/2"
Weight	0.33 kg (0.73 lb)
Load Bearing	2.0 kg (4.4 lb)
Operating Temperature	-40°C to +60°C (-40°F to +140°F)
Operating Humidity	<90% (RH)
Color	White
Applicable Model	Please see "Accessory Selection"

Dimensions (mm/inch)

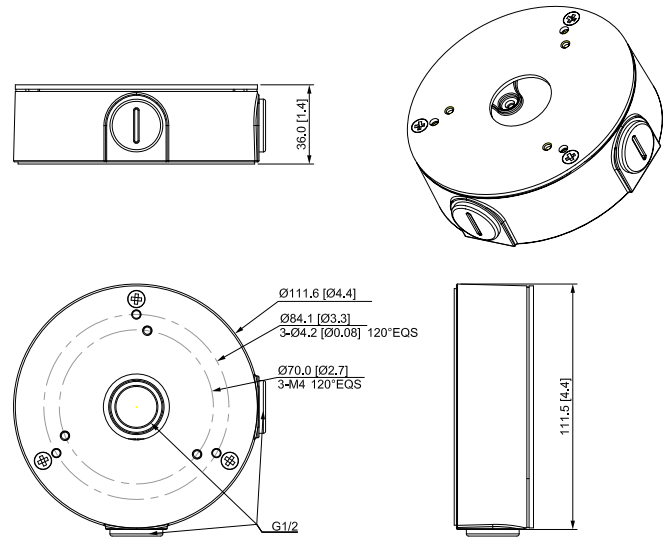

Ordering Information		
Type	Part Number	Description
Camera Mount	DH-PFA13G	Junction Box
Camera Mount	PFA13G	Junction Box

Package Information

- Junction box *1
- M4×10 screws *3
- ST4×25 screws *4
- Plastic expansion bolt *4
- S3.0 wrench *1
- G1/2 plastic waterproof connector *1

Installation

