

PFB720WA

Anti-Corrosion Wall Mount Bracket

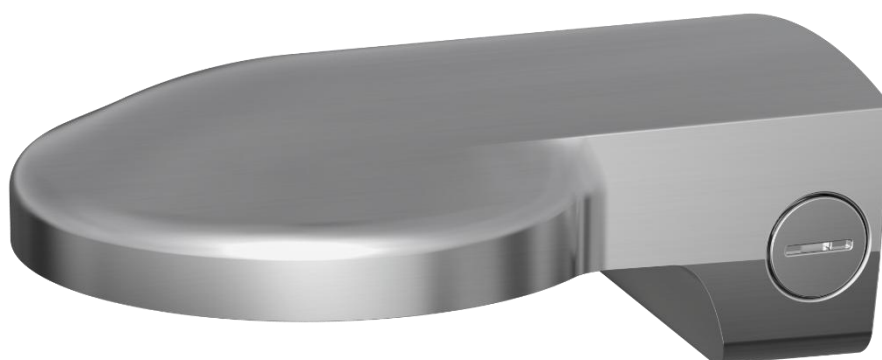

Features

- Material: 316L Stainless Steel
- Anti-Corrosion Wall Mount Bracket
- Neat & Integrated design

Technical Specifications

Model	PFB720WA
General	
Material	316L
Dimension (W x H x D)	231mmx172mmx85.8mm(9.09"x6.77"x3.38")
Weight	2.5kg(5.51lb)
Load Bearing	2.5kg(5.51lb)
Color	N/A
Operating Temperature	-40°C ~60°C(-40°F ~140°F)
Humidity	0~95% RH
Applicable Model	DH-IPC-HDBW8232EP-Z-SL, DH-IPC-HDBW8232EN-Z-SL

Order Information

Type	Part Number	Description
Camera mount	PFB720WA	Anti-Corrosion Wall Mount Bracket, no brand

Dimensions (mm/inch)

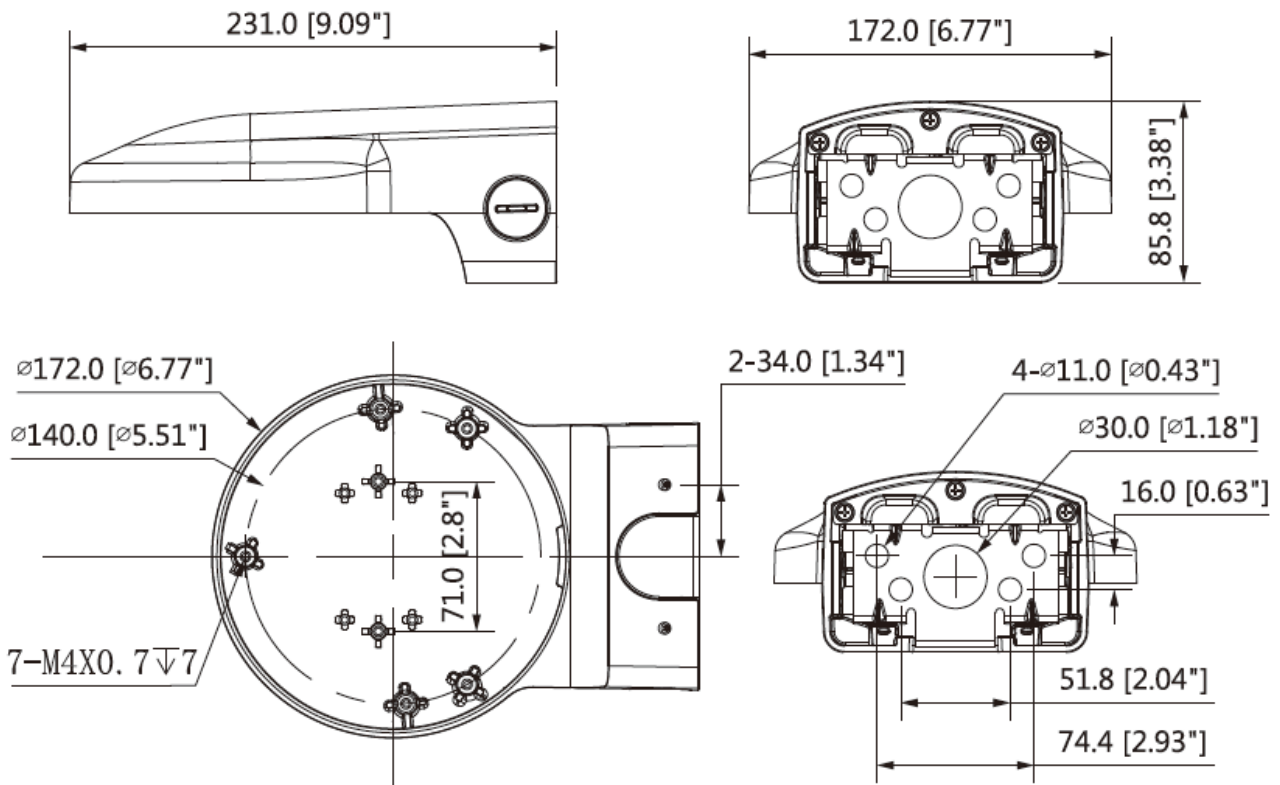

Application

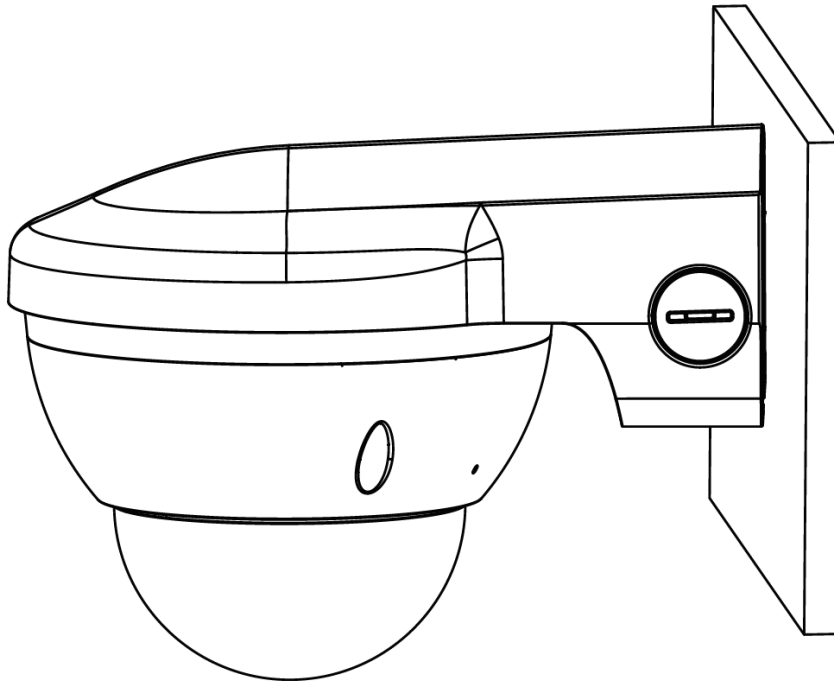

Package Information

- QSG * 1
- Mount Bracket * 1
- M8 X 80 Screw * 4
- M6 X 14 Screw * 2
- M4 X 10 Hexagon Socket Screw * 3
- M4 X 10 Cross Recessed Screw * 3

Package data	
Box Dimension	319mm × 229mm × 178mm (12.56"x9.01"x7.01")
Box Weight	2.9 kg (6.39lb)
Protective Box Dimension	559mm × 479mm × 351mm (22"x18.86"x13.82")
Box In Protective Box	6 In 1