

DS-1682ZJ-P

Extendable Pole for Pendant Mount



Feature

- Aluminum alloy with surface spray treatment
- Cooperate with the pendant mount (DS-1661ZJ, DS-1662ZJ)

Dimension

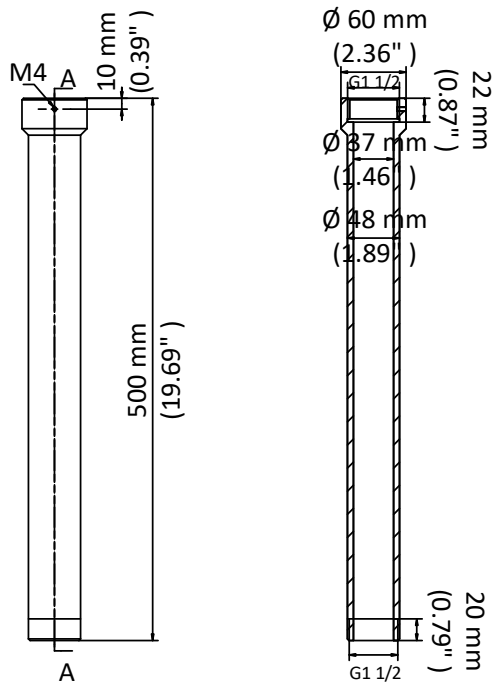

Available Model

DS-1682ZJ-P

Parameter

Model	DS-1682ZJ-P
Parameters	Extendable Pole for Pendant Mount
Appearance	Platinum Gray
Material	Aluminum Alloy
Dimension	$\varnothing 60$ mm \times 500 mm ($\varnothing 2.36$ " \times 19.69")
Weight	1050 g (2.31 lb.)

Note

- The mount should be installed on the flat surface.
- The waterproofing measures are necessary for the outdoor application.
- The wall must be capable of supporting at least 3 times as much as the total weight of the camera and the mount.
- The mount's maximum load capacity is 10 kg (22 lb.).